



Model N

Stainless Steel Double Wall
Positive Pressure Venting Systems
Special Gas Vent Applications

Model N is a single wall negative, neutral, or positive pressure pre-fabricated piping system intended for use in a variety of applications.

SPECIAL GAS VENT APPLICATIONS

- *Boilers*
- *Water Heaters*
- *Furnaces*



Tested and listed to
UL1738/ULC-S636

Table of Contents

UNDERWRITERS LABORATORIES LISTINGS

Model N in sizes 5" through 48" diameters have been tested and Listed (Safety Certified) by Underwriters Laboratories, Inc. (ULI) and bears the UL and/or c-UL logo signifying compliance with U.S. and/or Canadian standards. UL Listing product categories include:

(USA)

Special Gas Vent (UL1738)

(Canada)

Type BH Gas Vent (ULC-S636)

UL file numbers for Model G include
MH16161

CODE AND STANDARD COMPLIANCE

NFPA (NFPA, 31, 37, 54, 96, 211)
ICC (IMC, IFGC)
IAMPO (UMC)

ASSOCIATION/COMMITTEE PARTICIPATION



• System Overview	4-5
• Guide to Component Parts	6
• Product Identification	7
• Product Listings	
• Joint Assembly Parts	8-9
• Sealant	8
• Single Wall Pipe	10
• Adjustable/Variable Pipe	10
• Single Wall Fittings	11-13
• Connection Accessories	14
• Support/Guide Accessories	14-15
• Roof Penetrations/Terminations	16
• Technical Data	17-18

AMPCO Sizing/Pressure Calculations



Grand Rapids, MI 49512

Phone: 600-524-6524

www.ampcostacks.com

THE FOLLOWING CALCULATIONS ARE THEORETICAL AND ARE FOR REFERENCE ONLY TO ASSIST OUR CLIENTS. AMPCO ASSUMES NO RESPONSIBILITY FOR FIELD CLAIMS AGAINST THIS DATA. CALCULATIONS SHOULD BE VERIFIED BY A LICENSED HVAC PROFESSIONAL ENGINEER.

Run Date: 3/13/2017 2:42:02 EST

BOILER / APPLIANCE FLUE GAS CALCULATION

Fuel Type	1 - Natural Gas or Equivalent
MBTU Input (1000 / BTU)	3400 Per Hour
Ambient Temperature	70 Degrees F.
Flue Gas Temp. Rise Above Amb	280 Degrees F.
%CO2 in Combustion Products	9 %
Altitude Above Sea Level	0 Feet
Effective Height of System	19.5 Feet
Length of System (inc. height)	30 Feet

System sized for partial load

Vertical Manifold Tee:	0	Horizontal Manifold Tee:	0
45 Degree Lateral Tee:	0	90 Degree Tee:	0
15 Degree Elbow:	0	90 Degree Elbow:	0
45 Degree Elbow:	0	45 Degree Elbow:	3
Drain Sections:	0	Stack Drains:	0
Tapered Increases in Sys:	NO	Other System Resistance:	0
Tapered Reducers in Sys:	NO	Stepped Increases in Sys:	NO
Allowable Pressure:	NO	Stepped Reducers in Sys:	NO
Barometric Damper:	0	Pressure Changes:	0

Stack Cap Termination

Computer Sized at:	13.905 Inches
Ampco Product Size Selected:	16 Inches
Barometric Pressure @ Altitude:	29.92 Inches Hg
Density of Flue Gases:	0.049 lbs. / Foot ³
Theoretical Draft:	0.097 Inches H2O
Flue Gas %CO2 Used for Calcs:	9 %
Combustion Products Mass:	0.99 lbs. / MBTU
Flue Gas Mass Flow:	55.93 lbs. / min.
Flue Gas Volume Flow (CFM):	1150.8 Feet ³ / min
Flue Gas Velocity (@ Size):	13.74 Feet / Sec.
Total System Velocity Heads:	1.266 K
Total System Pressure Losses:	0.051 Inches H2O
Max. Pres. at System Entrance:	-0.046 Inches H2O

System Overview

AMPCO Model N is a modular, prefabricated venting system which embody flanged joints designed for both quick assembly and pressure-sealing capabilities. They offer structural accessories needed for support attachment to building structures.

Standard gas-carrying venting parts are usable for category II & IV Boiler, Water Heater, and Furnace applications.

Features and Benefits

- Factory-built for high quality, durability and long life
- Stainless steel single wall construction
- Safety tested and listed to multiple UL standards, signifying compliance with U.S. and Canadian codes
- 5" to 48" diameters (ID) to fit the wide range of commercial applications and customer specifications
- Array of components and accessories designed to make a complete installation simple and quick
- Selkirk 5-year limited warranty for Special Gas Vent applications

Complete Line of Fittings

Model N is available in eighteen sizes, from 5" I.D. to 48" I.D. Fittings include various elbows, tees, supports and terminations, as well as a variety of accessory fittings designed to make installation simple and quick.

Each component is shipped complete and ready for installation. Each ordered part includes Inner Vee Bands, and all the necessary hardware.

All items included with each order are listed in this catalog under the part description.



Exceeding the Requirements

AMPCO, inventors of the positive pressure system concept, far exceeds the requirements of codes and other manufacturers. Results of our testing programs illustrate this fact.

Leak Tests

AMPCO conducted system pressure testing (to 15" w.c.) against leakage in the presence of UL inspectors. Results of these tests are impressive. Using the OSHA occupation standard-of-leakage rate of 50 parts per million over an eight hour period as criterion for acceptance, the AMPCO system was tested to a leakage rate of only .144 parts per million, or three-tenths of one percent (.3%) of the maximum allowable leakage per UL.

Seismic Tests

We further demonstrated the superiority of the Model N concept by conducting seismic load tests. These tests proved the structural integrity of our products under severe stress by showing that a guyed stack measuring 20 inches in diameter and exceeding 10 feet above the guying location (installed in strict accordance with the UL103 Listing) could withstand the rigors of all seismic zones.

Structural Tests

AMPCO recently tested for greater freestanding limits (termination height above a guide point). These tests, simulating stack performance under 110 mph wind conditions, again demonstrated the superiority of AMPCO products.

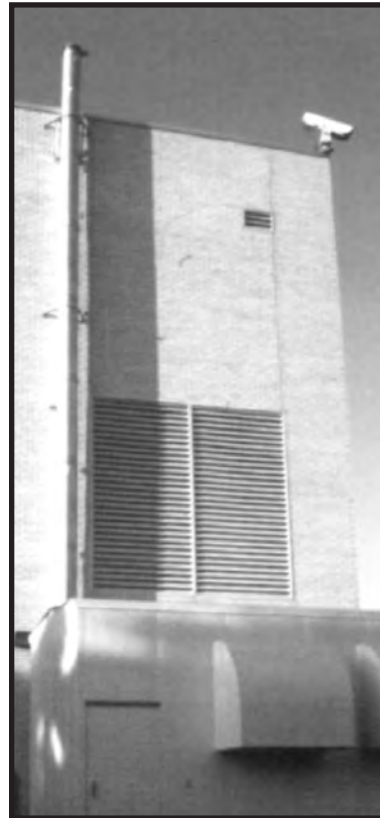

Guide to Component Parts

This page illustrates some of the major parts described on pages 8-16.

Product	Code	page	Product	Code	page	Product	Code	page
Joint Assembly Parts			Singal Wall Fittings (cont)			Support/Guide Accessories		
Overlapping Vee Band	VB	8	30° Elbow	EL30	12	Wall Support Assembly	WA	14
Special Gas Vent Sealant	SGV550	8	45° Elbow	EL45	12	Wall Guide Assembly	WG	14
Singal Wall Pipe			90° Elbow	EL90	12	Half Angle Ring	HR	15
60" Pipe Length	60	10	Drain Tee Cap	TC	13	Full Angle Ring	FR	15
42" Pipe Length	42	10	Clean Out Tee Cap	TCN	13	Plate Support Assembly	PA	15
30" Pipe Length	30	10	15° Elbow	EL15	13	Support Strap	SS	15
18" Pipe Length	18	10	Tapered Increaser	OT	13	Roof Penetrations/Terminations		
Adjustable/Variable Pipe			Step Increaser	OS	13	Ventilated Thimble	THB	15
30" Adjustable Pipe	AG30	10	Drain Section	DS	13	Ventilated Storm Collar	VSC	15
18" Adjustable Pipe	AG18	10	Eccentric Increaser	EOT	13	Ventilated Thimble Assembly	MVT	15
30" Variable Pipe	VL30	10	Slope Transition	ST	13	Storm Collar	SC	16
18" Variable Pipe	VL18	10	Connection Accessories			Tall Flashing	TF	16
Singal Wall Fittings			Seal Ring	SR	14	Pitched Tall Flashing	PTF	16
90° Tee	MT	11	Flanged Hood Transition	TS	14	Rain Cap	CCA_RC	16
45° Tee - Lateral	JL	11	Unflanged Hood Transition	TSU	14	Stack Cap	SK	16
90° Wye	JY	11	Fan Adapter	FA	14	Exit Cone	EC	16

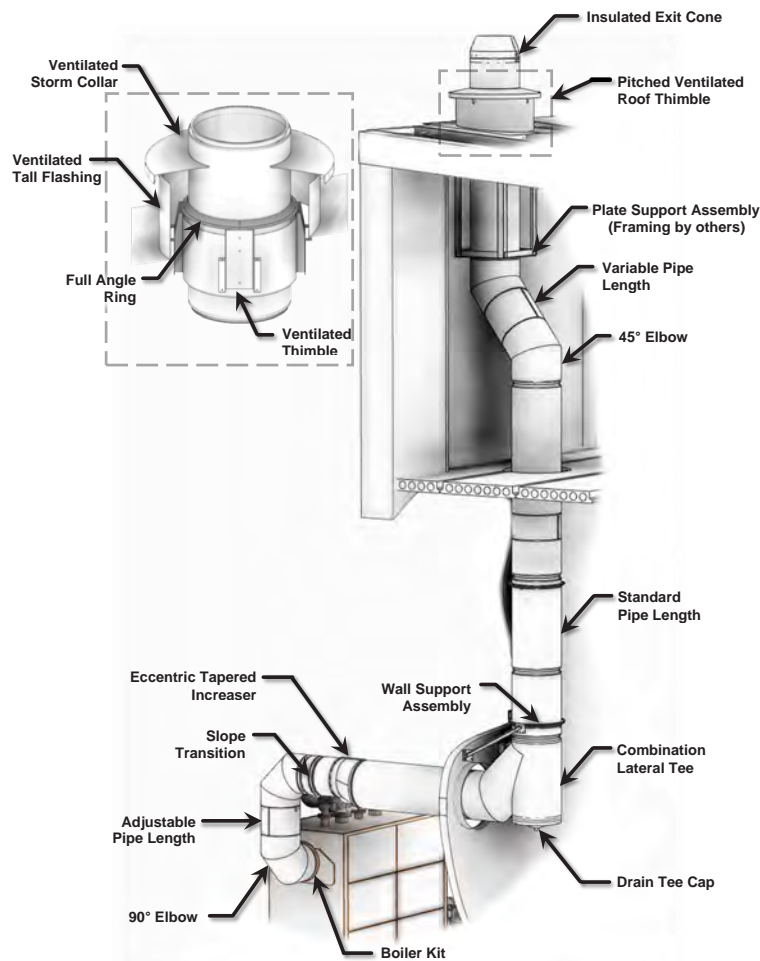



Understanding Product Codes and Part Numbers (Example: 6N316-AG30)

All parts manufactured by AMPCO are identified by a series of numbers and letters which describe their makeup and function.

Here is how to interpret the Part Number designation for Model N products.

1. It begins with the pipe or fitting's internal diameter (in inches) such as 8, 22, 36, etc.
2. This is followed by the Model designation, N.
3. Next, is the product's Material designation, 316.
4. Then, following a dash, the product Code name is listed, such as AG30, JY, or MVT.

(For Product Code listings, refer to page 6.)

Thus, the Ordered Part Number for a 30-inch Adjustable Pipe, with a 6-inch I.D., made of 316 Stainless Steel inner is listed:

6N316- AG30

* Note: For products with reduction or increaser parts, the part number changes as follows:

OT - Smaller diameter listed first (before Model designation)
Larger diameter listed before Code designation

Example - For a Tapered Increaser with an 8" to 16" dia. Body:

8N316-16OT

Overlapping Vee Band

Code:
VB

Vee Band for connecting inner 1/2" rolled flanges. Capable of holding 15" w.c. of pressure when properly installed.



Materials Available:

All Stainless Construction

Notes:

1. VB's are a one or two-piece design. Included with pipe sections.

Sealant

Code: SGV550

SGV550 Sealant is for 550° F. maximum flue gas temperatures, and is applied to the VEE band and pipe flange before connecting two pipes at installation.



Sealant Coverage

Expected Number of Joints Sealed Per Tube

Inner Dia. (inches)	SGV550
5/6	10
8/10	9
12	8
14/16	7
18/20	6
22/24	5
26/28	4
30/32	3
36	2
42/48	1

Joint Assembly

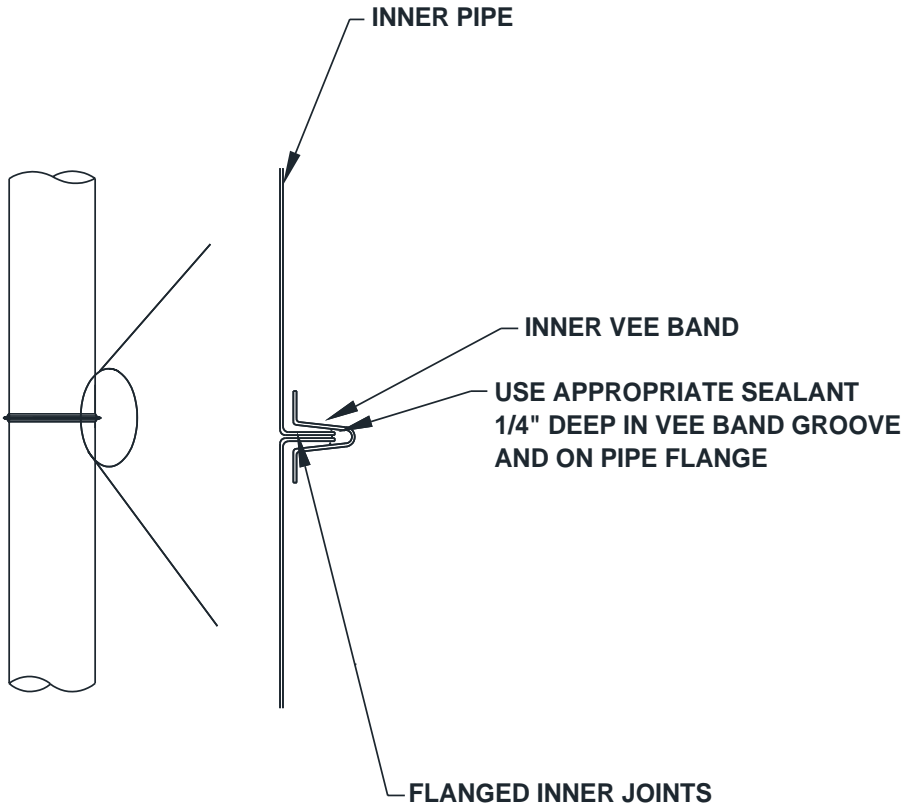

Single Wall Pipe

Standard Length CODE: 18, 30, 42 & 60

A variety of straight pipe lengths are available with Model N. Special lengths are also available and can be made with a minimum dimension of 6" long.

- 18" & 30" lengths** available in all diameters 5"- 48"
- 42" lengths** available in 6"-42" diameters
- 60" lengths** available in 8"-14" diameters
- 59" lengths** available in 16"-26" diameters

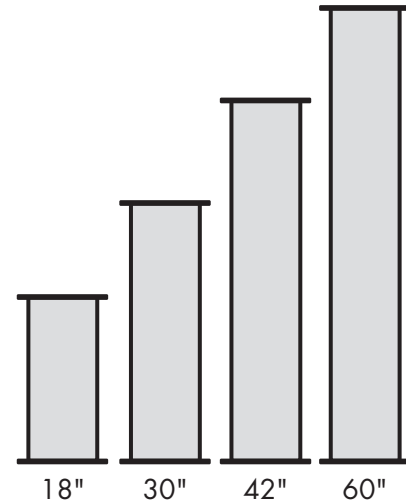

Adjustable Single Wall Pipe

Adjustable Length CODE: AG18 & AG30

USE: The N-AG18/30 is used for thermal expansion compensation in any pipe line running between two fixed points.

NOTE: For diameters over 26", part G-AG30 must be used.

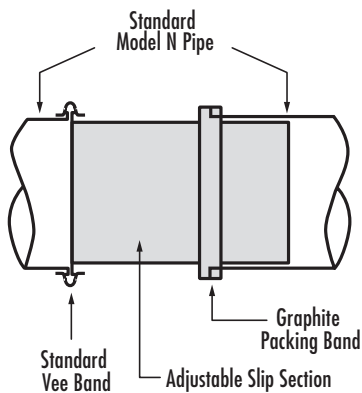

- 18" Adjustable length**
available in 5"-26" diameters
- 30" Adjustable length**
available in 5"-48" diameters

Flow Resistance Factor is the same as standard pipe.

NOTE:

1. Minimum installed length is 4".
2. AG 18 not available for 28" diameter and above.
3. Maximum installed space is when the inner slip section protrudes at least 1/2 pipe diameter into the adjacent pipe.
4. Flow Resistance Factor (K) is the same as insulated pipe lengths.

Variable Length CODE: AG18 & AG30

USE: Part N-VL18 is used as length to fill odd dimensions of 4" to 14". Part N-VL30 is used to fill odd dimensions of 4" to 26".

NOTE: N-VL does not allow for thermal expansion.

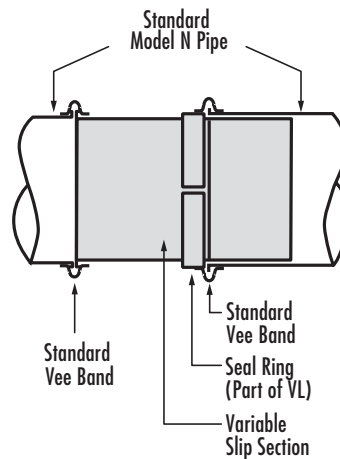

- 18" Adjustable length**
available in 5"- 48" diameters

Flow Resistance Factor is the same as standard pipe.

90° Tee CODE: MT

USE: To join horizontal and vertical sections of pipe. The N-MT provides for connection for a drain or inspection fitting.

NOTE: A reduction Manifold Tee is offered.

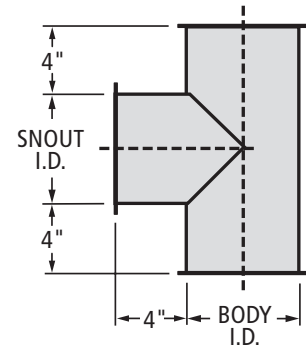

K = 1.25 Flow Resistance Factor

45° Lateral Tee CODE: JL

USE: The N-JL is used to join horizontal and vertical sections of pipe at a 45 degree angle.

NOTE: A reduction N-JL is offered. A, B, and C dimensions would remain the same.

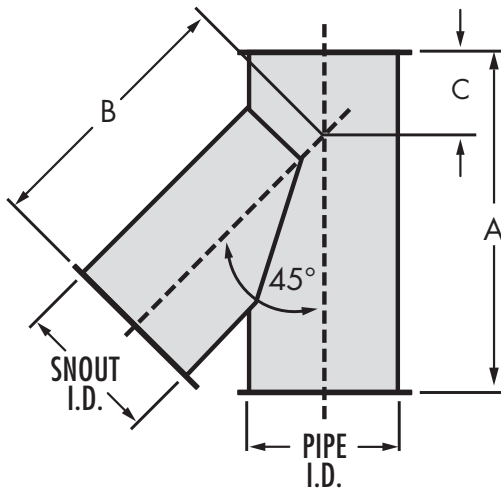

Part No.	Pipe Size I.D.	Dim. A	Dim. B	Dim. C
5N-JL	5"	19 ¹ / ₂	13 ³ / ₄	5 ³ / ₄
6N-JL	6"	19 ¹ / ₂	13 ³ / ₄	5 ³ / ₄
8N-JL	8"	22 ⁷ / ₈	16 ⁵ / ₈	6 ¹ / ₄
10N-JL	10"	24 ¹ / ₁₆	19	5 ¹ / ₁₆
12N-JL	12"	26 ¹⁵ / ₁₆	21 ⁷ / ₁₆	5 ¹ / ₂
14N-JL	14"	29 ³ / ₄	23 ⁷ / ₈	5 ⁷ / ₈
16N-JL	16"	32 ⁹ / ₁₆	26 ¹ / ₄	6 ⁵ / ₁₆
18N-JL	18"	35 ³ / ₈	28 ³ / ₄	6 ³ / ₄
20N-JL	20"	38 ³ / ₁₆	31 ¹ / ₁₆	7 ¹ / ₈
22N-JL	22"	43 ⁷ / ₈	35 ⁷ / ₈	8
24N-JL	24"	43 ⁷ / ₈	35 ⁷ / ₈	8
26N-JL	26"	49 ⁹ / ₁₆	40 ³ / ₄	8 ¹³ / ₁₆
28N-JL	28"	49 ⁹ / ₁₆	40 ³ / ₄	8 ¹³ / ₁₆
30N-JL	30"	55 ³ / ₁₆	45 ⁹ / ₁₆	9 ⁷ / ₈
32N-JL	32"	55 ³ / ₁₆	45 ⁹ / ₁₆	9 ⁵ / ₈
36N-JL	36"	60 ¹³ / ₁₆	50 ³ / ₈	10 ⁷ / ₁₆
42N-JL	42"	69 ¹⁵ / ₁₆	58 ¹ / ₄	11 ³ / ₄
48N-JL	48"	79 ³ / ₁₆	66 ⁷ / ₈	13

K = 0.4 Flow Resistance Factor

90° Wye CODE: JY

USE: The N-JY is intended for low pressure drop joining of two appliances.

NOTE: All openings are the same size diameter.

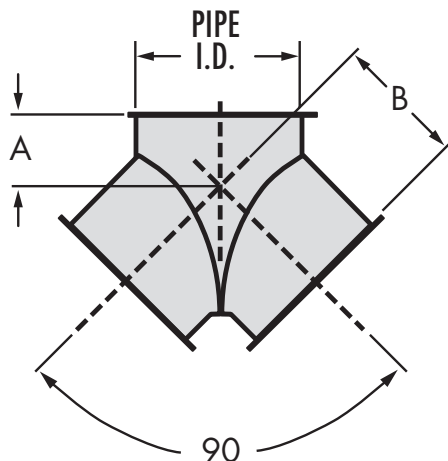

Part No.	Pipe Size I.D.	Dim. A	Dim. B
5N-JY	5"	4 ⁵ / ₈	9
6N-JY	6"	4 ⁵ / ₈	9
8N-JY	8"	5 ¹ / ₁₆	10
10N-JY	10"	5	11
12N-JY	12"	5 ¹ / ₂	12
14N-JY	14"	5 ⁷ / ₈	13
16N-JY	16"	6 ³ / ₈	14
18N-JY	18"	6 ⁵ / ₈	15
20N-JY	20"	7 ¹ / ₈	17
22N-JY	22"	8	19
24N-JY	24"	8	19
26N-JY	26"	8 ³ / ₄	22
28N-JY	28"	8 ³ / ₄	22
30N-JY	30"	9 ⁵ / ₈	24
32N-JY	32"	9 ⁵ / ₈	24
36N-JY	36"	10 ¹ / ₂	27
42N-JY	42"	11 ³ / ₄	31
48N-JY	48"	13	34

K = 0.6 Flow Resistance Factor

Single Wall Fittings

30° Fixed Elbow CODE: EL30

USE: Designed to change the direction of a breeching 30 degrees in a vertical or horizontal run.

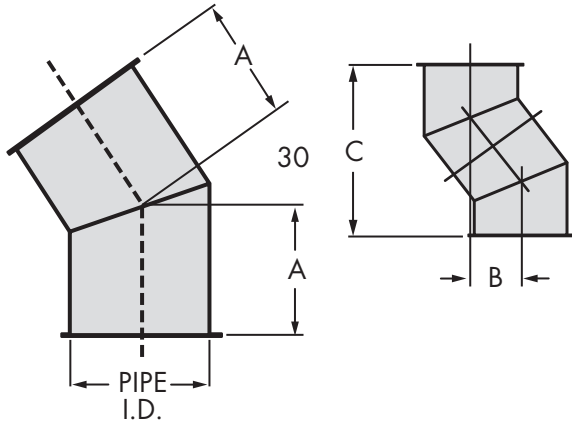

Part No.	Pipe Size I.D.	Dim. A	Dim. B	Dim. C
5N-EL30	5"	6 ¹ / ₈	6 ¹ / ₈	22 ³ / ₈
6N-EL30	6"	6 ¹ / ₈	6 ¹ / ₈	22 ⁷ / ₈
8N-EL30	8"	6 ³ / ₈	6 ³ / ₈	22 ⁷ / ₈
10N-EL30	10"	6 ¹¹ / ₁₆	6 ¹¹ / ₁₆	24 ⁷ / ₈
12N-EL30	12"	7 ⁵ / ₁₆	7 ⁵ / ₁₆	27 ¹ / ₄
14N-EL30	14"	7 ⁷ / ₈	7 ⁷ / ₈	29 ⁵ / ₈
16N-EL30	16"	8 ¹ / ₄	8 ¹ / ₄	30 ⁵ / ₈
18N-EL30	18"	8 ⁵ / ₈	8 ⁵ / ₈	31 ⁵ / ₈
20N-EL30	20"	9 ¹ / ₈	9 ¹ / ₈	34 ¹ / ₈
22N-EL30	22"	9 ³ / ₈	9 ³ / ₈	35
24N-EL30	24"	10 ¹ / ₁₆	10 ¹ / ₁₆	37 ¹ / ₂
26N-EL30	26"	10 ⁹ / ₁₆	10 ⁹ / ₁₆	38 ¹ / ₂
28N-EL30	28"	11	11	40 ⁷ / ₈
30N-EL30	30"	11 ¹ / ₄	11 ¹ / ₄	41 ⁷ / ₈
32N-EL30	32"	11 ⁷ / ₈	11 ⁷ / ₈	44 ³ / ₈
36N-EL30	36"	12 ⁷ / ₈	12 ³ / ₄	47 ³ / ₄
42N-EL30	42"	14	14	52 ¹ / ₂
48N-EL30	48"	14 ³ / ₁₆	14 ³ / ₁₆	56 ⁷ / ₁₆

K = 0.12 Flow Resistance Factor

45° Fixed Elbow CODE: EL45

USE: The N-EL45 is used to join horizontal and vertical sections of pipe at a 45 degree angle.

NOTE: A reduction N-JL is offered. A, B, and C dimensions would remain the same.

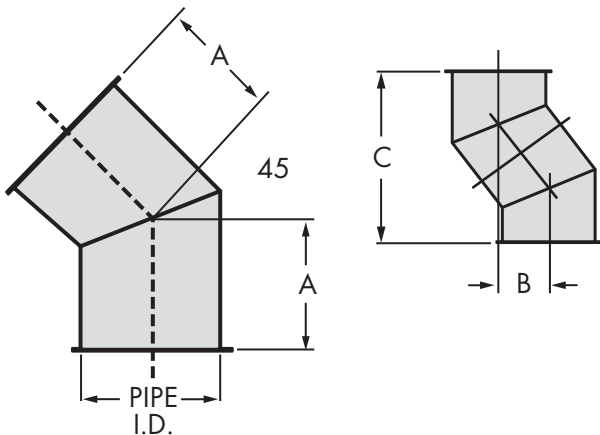

Part No.	Pipe Size I.D.	Dim. A	Dim. B	Dim. C
5N-EL45	5"	8 ¹ / ₂	12	29
6N-EL45	6"	8 ¹ / ₂	12	29
8N-EL45	8"	8 ¹⁵ / ₁₆	12 ⁵ / ₈	30 ⁷ / ₁₆
10N-EL45	10"	9 ⁵ / ₁₆	13 ³ / ₁₆	31 ⁷ / ₈
12N-EL45	12"	10 ¹ / ₄	14 ¹ / ₂	35
14N-EL45	14"	10 ¹¹ / ₁₆	15 ¹ / ₈	36 ¹ / ₂
16N-EL45	16"	11 ⁹ / ₈	16 ⁷ / ₁₆	39 ⁵ / ₈
18N-EL45	18"	12 ¹ / ₁₆	17 ¹ / ₁₆	41 ¹ / ₈
20N-EL45	20"	13	18 ³ / ₈	44 ¹ / ₄
22N-EL45	22"	13 ⁵ / ₁₆	18 ¹³ / ₁₆	45 ¹ / ₂
24N-EL45	24"	14 ¹ / ₁₆	20 ¹ / ₄	48 ¹ / ₈
26N-EL45	26"	14 ⁷ / ₈	21 ¹ / ₁₆	50 ⁷ / ₈
28N-EL45	28"	15 ¹ / ₁₆	22 ³ / ₁₆	53 ¹ / ₂
30N-EL45	30"	16 ¹ / ₄	22 ⁵ / ₁₆	53 ³ / ₈
32N-EL45	32"	17	24	58
36N-EL45	36"	18 ³ / ₈	25 ¹⁵ / ₁₆	62 ⁵ / ₈
42N-EL45	42"	19 ¹ / ₁₆	27 ⁷ / ₈	67
48N-EL45	48"	21 ⁷ / ₁₆	30 ⁵ / ₁₆	74 ⁷ / ₈

K = 0.15 Flow Resistance Factor

90° Fixed Elbow CODE: EL90

USE: The N-EL90 is used to join horizontal and vertical sections of pipe at a 90 degree angle.

NOTE: All openings are the same size diameter.

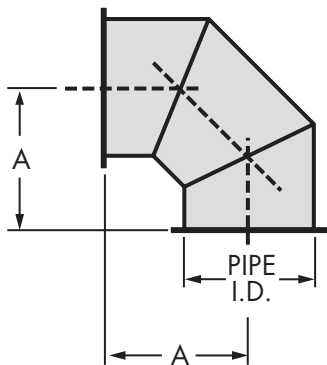

Part No.	Pipe Size I.D.	Dim. A
5N-EZ90	5"	11 ¹ / ₂
6N-EL90	6"	11 ¹ / ₂
8N-EL90	8"	12 ¹ / ₂
10N-EL90	10"	13 ¹ / ₂
12N-EL90	12"	14 ¹ / ₂
14N-EL90	14"	15 ¹ / ₂
16N-EL90	16"	16 ¹ / ₂
18N-EL90	18"	17 ¹ / ₂
20N-EL90	20"	18 ¹ / ₂
22N-EL90	22"	19 ¹ / ₂
24N-EL90	24"	20 ¹ / ₂
26N-EL90	26"	21 ¹ / ₂
28N-EL90	28"	22 ¹ / ₂
30N-EL90	30"	23 ¹ / ₂
32N-EL90	32"	24 ¹ / ₂
36N-EL90	36"	26 ¹ / ₂
42N-EL90	42"	29 ¹ / ₂
48N-EL90	48"	32 ¹ / ₂

K = 0.30 Flow Resistance Factor

15° Elbow

USE: Two-piece Elbow can establish many different degrees when combined with other standard Elbows.

CODE: EL15

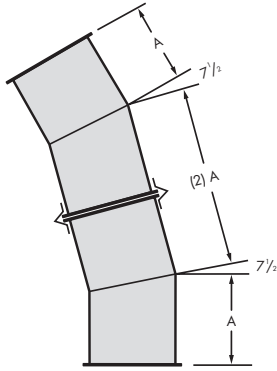

Part No.	A
5N-EL15	4 ³ / ₁₆ "
6N-EL15	4 ³ / ₁₆ "
8N-EL15	4 ¹ / ₄ "
10N-EL15	4 ⁹ / ₁₆ "
12N-EL15	4 ⁷ / ₁₆ "
14N-EL15	4 ¹ / ₂ "
16N-EL15	4 ⁹ / ₁₆ "
18N-EL15	4 ⁵ / ₈ "
20N-EL15	4 ¹¹ / ₁₆ "
22N-EL15	4 ³ / ₄ "
24N-EL15	4 ¹³ / ₁₆ "
26N-EL15	4 ⁷ / ₈ "
28N-EL15	4 ¹⁵ / ₁₆ "
30N-EL15	5"
32N-EL15	5 ¹ / ₁₆ "
36N-EL15	5 ³ / ₁₆ "
42N-EL15	5 ³ / ₈ "
48N-EL15	5 ⁹ / ₁₆ "

K = 0.06 flow resistance factor

Tapered Increaser/Reducer

USE: Used when a pipe diameter change is required. Make sure condensate build-up in larger diameter is drained away downstream of increaser.

CODE: OT

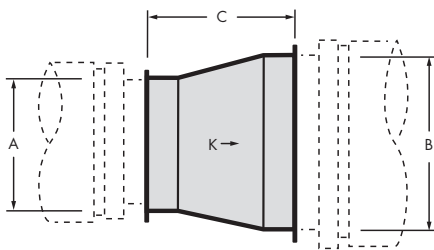

Dimensions:

A = Smaller Diameter

B = Larger Diameter

C = Installed Length = [(B-A) 2] + 2 (see Note 1 below)

Example:

Installed Length for 12N304-18OT equals [(18-12)2] + 2 = 14 inches.

Notes:

1. Installed length shall not be greater than longest available straight pipe length.

2. $K = N [1 - (A/B)^2]$

where N = 0.47 for one step OT

N = 0.53 for one step OT

Slope Transition

USE: Used to create immediate 1/4" on 12" slope on horizontal runs. Typically used in pairs (one at lower (inlet) end, other at upper (outlet) end of sloped [1/4 on 12] horizontal run)

CODE: ST

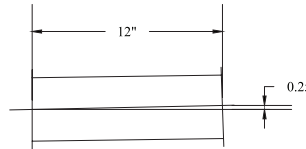

Cleanout Tee Cap

USE: Used to close Tee opening at the base of a stack or the end of a horizontal run.

CODE: TCN

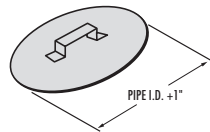

Part No. (pipe I.D.) N-TCN

Includes one VB

Drain Tee Cap

USE: Provides a drain at the base of a vertical chimney when connected to the MT or JL

CODE: TC

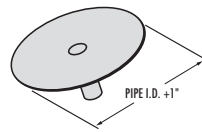

Part No. (pipe I.D.) N-TC

1" N.P.T. nipple on 5"- 20" sizes

2" N.P.T. nipple on 22"- 48" sizes

Includes one VB

Drain Section DS

USE: Used with open stack terminations for draining off rain water from inside vertical or horizontal flue.

CODE: DS

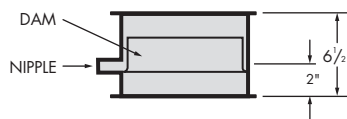

K = 0.25 flow resistance factor

Step Increaser/Reducer

USE: Used when pipe diameter change is required in a small space. Make sure condensate build-up in large diameter is drained away downstream of increaser.

CODE: OS

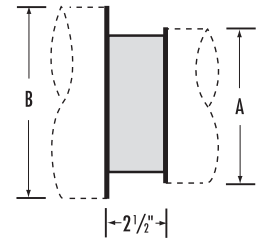

Dimensions:

A = Smaller Diameter

B = Larger Diameter

Notes:

1. This is a non-structural part; use only if OT will not fit within the allowable space.

2. $K = N [1 - (A/B)^2]$

Eccentric Increaser

USE: The primary increaser used for changing diameters, due to flat bottom for effective condensate flow back to drain.

CODE: EOT

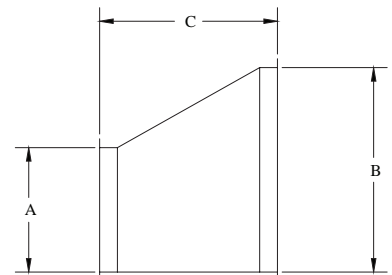

Dimensions:

A = Smaller Diameter

B = Larger Diameter

C = Installed Length = [(B-A) 2] + 2 (see Note 1 below)

Example:

Installed Length for 12P304-18OT equals [(18-12)2] + 2 = 14 inches.

Notes:

1. Installed length shall not be greater than longest available straight pipe length.

2. $K = N [1 - (A/B)^2]$

where N = 0.47 for one step EOT

N = 0.53 for one step EOT

Connection Accessories

Fan Adapter FA

USE: Designed to secure Model N to fan inlet.

CODE: FA

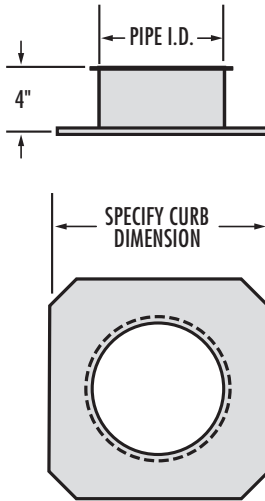

Hood Transition

USE: Securing Model N to flanged appliance outlets.

CODE: TS

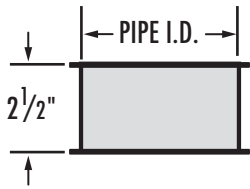

Hood Transition (Unflanged)

USE: Securing Model N to unflanged appliance outlets.

CODE: TSU

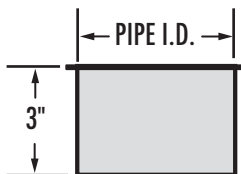

Joint Assembly Parts

Seal Ring

USE: Used for non-welded attachment to appliances having an unflanged or collar outlet.

CODE: SR

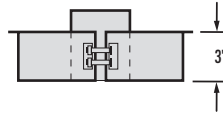

Support/Guide Accessories

Wall Guide Assembly

USE: Same use as FR, but with factory-supplied bracing.

CODE: WG

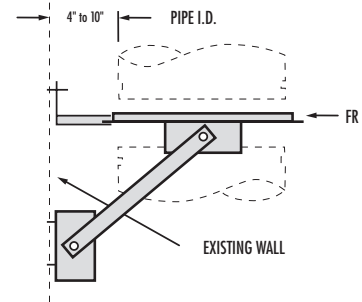

Ordered Part Included:

One FR, four struts, and six brackets.

Notes:

1. Assembly will maintain a 6" to 11" clearance between pipe I.D. and supporting structure.

Materials Available:

Painted Steel

Wall Support Assembly

USE: "Limited" support assembly with factory-supplied bracing.

CODE: WA

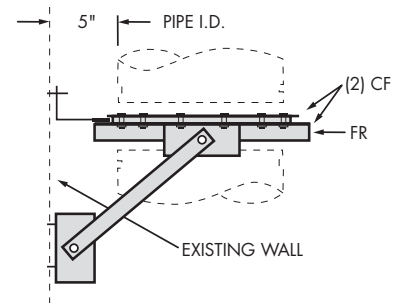

Ordered Part Includes:

One FR, two CFs, two HCBs, five brackets, two struts, and all hardware except connection at wall.

Notes:

1. Assembly will maintain a 5" clearance between pipe I.D. and supporting structure.

Materials Available:

Painted Steel

Plate Support Assembly

USE: Used for supporting the load of the stack and as a fixed point anchor near fittings.

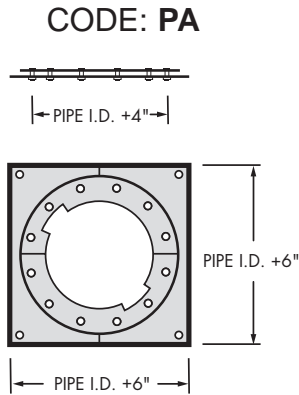

Ordered Part Includes:

Split (square) plate, one CF, two HCBs and hardware.

Plate Thickness:

- 0.188" for sizes 5" through 20" I.D. diameters
- 0.250" for sizes 22" through 36" I.D. diameters
- 0.375" for sizes 42" through 48" I.D. diameters

Notes:

- Two 316 Stainless Steel HCBs should be ordered separately for stainless steel outer projects.
- PA fabricated from 304 Stainless Steel is available upon request and is non-returnable. Allow extra manufacturing time.

Materials Available:

Painted Steel

Support Strap

USE: Available in 5" through 28"—N only. 0.188" Thick Rolled Steel.

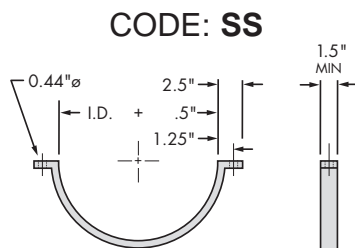

Materials Available:

Painted Steel

Angle Rings

USE: Used for guiding and/or supporting horizontal installations.

CODE: HR & FR

HR - Half Ring
FR - Full Ring

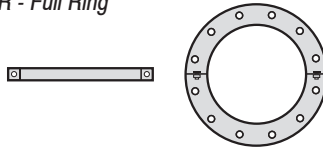

Part No.	Bolt Hole	I.D. of Ring	# of Holes	Size of Angle	Angle
5N-HR	9	5 ¹ / ₈	6	(1)	45
6N-HR	10	6 ¹ / ₈	6	(1)	45
8N-HR	12	8 ¹ / ₈	6	(1)	45
10N-HR	14	10 ¹ / ₈	6	(1)	45
12N-HR	16	12 ¹ / ₈	6	(1)	45
14N-HR	18	14 ¹ / ₈	6	(1)	45
16N-HR	20	16 ¹ / ₈	6	(1)	45
18N-HR	22	18 ¹ / ₈	6	(1)	45
20N-HR	24	20 ¹ / ₈	6	(1)	45
22N-HR	26	22 ¹ / ₈	10	(2)	22.5
24N-HR	28	24 ¹ / ₈	10	(2)	22.5
26N-HR	30	26 ¹ / ₈	10	(2)	22.5
28N-HR	32	28 ¹ / ₈	10	(2)	22.5
30N-HR	34	30 ¹ / ₈	10	(2)	22.5
32N-HR	36	32 ¹ / ₈	10	(2)	22.5
36N-HR	40	36 ¹ / ₈	10	(2)	22.5
42N-HR	46	42 ¹ / ₈	10	(2)	22.5
48N-HR	52	48 ¹ / ₈	10	(2)	22.5

- (1) Size of Angle = 1¹/₂ X 1¹/₂ X 3⁸/₁₆
- (2) Size of Angle = 2 X 2 X 3⁸/₁₆

Materials Available:

Painted Steel

Ventilated Thimble

USE: Body part of MVT, MRS, and PVT. Also can be used by itself for a wall penetration (see installation instructions). Refer to table on right for all necessary parts.

CODE: THB

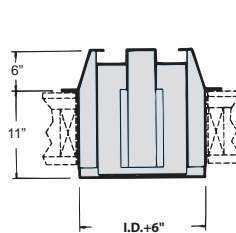

Framing Dimension

Ventilated Storm Collar

USE: Combustible wall penetration. Due to flange on pipe the VSC must be up sized. Additional Storm Collar must be used to close the gap. Refer to table below for VSC and SC parts.

CODE: VSC

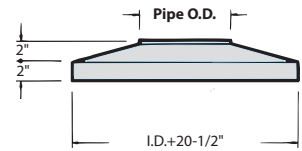

Ventilated Roof Thimble

USE: For use where pipe passes through a combustible roof or structure. Also guides the chimney 6" above the roof line. Refer to table below for all necessary parts.

CODE: MVT

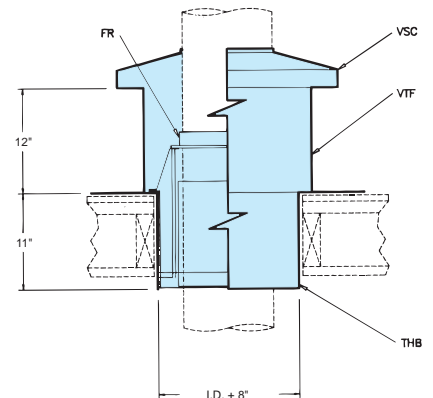

Pipe Size I.D.	THB Part No.	MVT Part No.	VSC Part No.	SC Part No.
5	5P-THB	5P-MVT	5P-VSC	5G-SC
6	6P-THB	6P-MVT	6P-VSC	6G-SC
8	8P-THB	8P-MVT	8P-VSC	8G-SC
10	10P-THB	10P-MVT	10P-VSC	10G-SC
12	12P-THB	12P-MVT	12P-VSC	12G-SC
14	14P-THB	14P-MVT	14P-VSC	14G-SC
16	16P-THB	16P-MVT	16P-VSC	16G-SC
18	18P-THB	18P-MVT	18P-VSC	18G-SC
20	20P-THB	20P-MVT	20P-VSC	20G-SC
22	22P-THB	22P-MVT	22P-VSC	22G-SC
24	24P-THB	24P-MVT	24P-VSC	24G-SC
26	26P-THB	26P-MVT	26P-VSC	26G-SC
28	28P-THB	28P-MVT	28P-VSC	28G-SC
30	30P-THB	30P-MVT	30P-VSC	30G-SC
32	32P-THB	32P-MVT	32P-VSC	32G-SC
36	36P-THB	36P-MVT	36P-VSC	36G-SC
42	42P-THB	42P-MVT	42P-VSC	42G-SC
48	48P-THB	48P-MVT	48P-VSC	48G-SC

Roof Penetrations

Storm Collar

USE: Used above the TF and PTF for complete weatherization above the roof.

CODE: SC

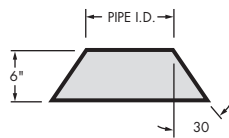

Notes:

1. Requires P600 sealant when installing.

Materials Available:

Aluminized or Galvanized Steel	304	316
--------------------------------	-----	-----

Rain Cap (Heatfab Saf-T Vent)

USE: Provides the greatest degree of wind protection and required for use on Category II applications. Sizes available are from 5"-32". Rain cap adapts to G pipe models via the following parts ordered separately: Saf-T Vent Double Flange Adapter (CCA_PS) and Vee-Band (VB). Reference illustration and table below.

CODE: CCA_RC

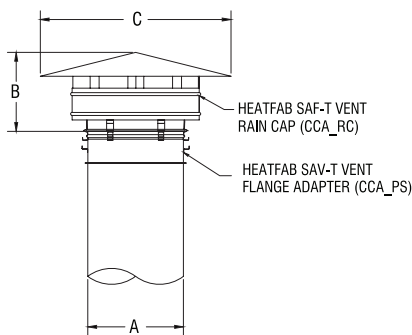

Product (Pipe I.D.)	Saf-T Vent Rain Cap Part Number	Saf-T Vent Flange Adapter Part Number	Dimensions		
			A	B	C
5	CCA05RC	CCA05PS	5	8.5	14
6	CCA06RC	CCA06PS	6	8.5	14
8	CCA08RC	CCA08PS	8	9.5	18
10	CCA10RC	CCA10PS	10	9.5	20
12	CCA12RC	CCA12PS	12	9.5	24
14	CCA14RC	CCA14PS	14	11.5	28
16	CCA16RC	CCA16PS	16	13.5	32
18	CCA18RC	CCA18PS	18	15.5	36
20	CCA20RC	CCA20PS	20	17.5	36
22	CCA22RC	CCA22PS	22	19.5	44
24	CCA24RC	CCA24PS	24	19.5	48
26	CCA26RC	CCA26PS	26	25	52
28	CCA28RC	CCA28PS	28	25	52
30	CCA30RC	CCA30PS	30	25	52
32	CCA32RC	CCA32PS	32	25	52

Tall Flashing TF

USE: Used in conjunction with SC for weatherization at the roof.

CODE: TF

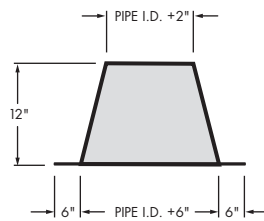

Notes:

1. Use limited to installations where complete roof penetration is non-combustible.

Materials Available:

Aluminized or Galvanized Steel	304	316
--------------------------------	-----	-----

Stack Cap

USE: Provides partial protection with low flow resistance. May require a drain at base of stack. Not permitted for CAT II applications.

CODE: SK

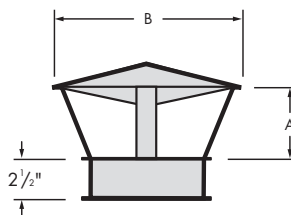

K = 0.5 Flow Resistance Factor

Part No.	Dim. A	Dim. B
5N-SK	2 1/2	10 1/4
6N-SK	3	10 1/4
8N-SK	4	13 3/8
10N-SK	5	17
12N-SK	6	20 1/2
14N-SK	7	24
16N-SK	8	27 3/8
18N-SK	9	30 3/4
20N-SK	10	34 1/8
22N-SK	11	37 5/8
24N-SK	12	41
26N-SK	13	44 3/8
28N-SK	14	47 7/8
30N-SK	15	51 1/4
32N-SK	16	54 5/8
36N-SK	18	61 1/2
42N-SK	21	71 3/4
48N-SK	24	82

Pitched Tall Flashing PTF

USE: Same function as TF, except for use on a pitched roof.

CODE: PTF

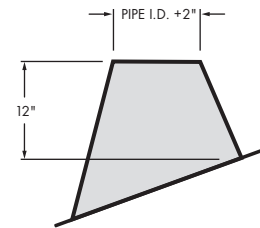

Notes:

1. Part is non-returnable and may require extra manufacturing time. Specify pitch when ordering.
2. Use limited to installations where complete roof penetration is non-combustible.

Materials Available:

Aluminized or Galvanized Steel	304	316
--------------------------------	-----	-----

Exit Cone

USE: Will increase stack exit velocity 1 1/2 times. Requires a drain at the bottom of stack.

CODE: EC

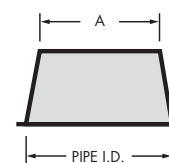

K = 0.5 Flow Resistance Factor

Part No.	Dim. A
5N-EC	4 7/8
6N-EC	4 7/8
8N-EC	6 9/16
10N-EC	8 3/16
12N-EC	9 7/8
14N-EC	11 1/2
16N-EC	13 1/16
18N-EC	14 3/4
20N-EC	16 5/16
22N-EC	18
24N-EC	19 5/8
26N-EC	21 1/4
28N-EC	2 7/8
30N-EC	24 1/2
32N-EC	26 1/8
36N-EC	29 3/8
42N-EC	34 5/16
48G-EC	39 3/16

Material Thickness

Diameter	Inner	
	Gauge *	Material
5"-32"	20	.035" - 316 SS
	20	
36"	20	.035" - 316 SS
	20	
38"-48"	18	.048" - 316 SS
	18	

* Gauge is approximate.

Operating Temperatures and Clearances to Combustibles

Table I-1: Model N316 Min. Airspace Clearance-to-Combustible Construction					
Model	Pipe ID	Max. Appliance Operating Temperature	Clearance to Combustible Material	Orientation	Enclosure
N	5-12"	230°F*	0"	Vert. & Horiz.	Fully Enclosed
	14-48"	194°F*			
	5"	550°F	1"	Vert. & Horiz.	Unenclosed
	6-12"		2"		
	14"		3"		
	16-18"		4"		
	20-22"		5"		
	24-26"		6"		
	28-32"		7"		
	34-38"		8"		
	40-44"		9"		
	46-48"		10"		
	5-48"		0"		

* Permitted to be fully enclosed with combustibles at 0" clearance per ULC-S636

WE BUILD TO YOUR DESIGN



Model N Single Wall Venting Systems

Special Gas Vent
UL1738/ULC-S636 Applications

- Boilers
- Water Heaters
- Furnaces



AMPCO manufactures engineered solutions for venting today's high-efficiency combustion installations. AMPCO engineered systems are manufactured of high technology materials which resist the highly corrosive effects of combustion exhaust. Traditional methods require time-consuming, labor-intensive installations which consume valuable building space and which later require expensive routine maintenance. Utilizing a system of both standard pre-engineered products with custom-manufactured components, AMPCO engineers a cost-effective venting system which consumes little space and which assembles easily in the field.

A full line of the finest products is yours
from Hart & Cooley Inc
HeatFab
Ward Industries
Milcor
Portals Plus
Roof Products & Systems



COMMERCIAL: INDUSTRIAL VENT | CHIMNEY



ampcostacks.com

Hart & Cooley, Inc.
5030 Corporate Exchange Blvd. • Grand Rapids, MI. 49512
1.800.624.8642 phone • 1.800.972.1421 fax
Quote Requests - ampco.quoting@hartcool.com

Canada Contact Info:
375 Green Rd
Stoney Creek, ON L8E 4A5
1.888.735.5475 phone
1.866.835.9624 fax